

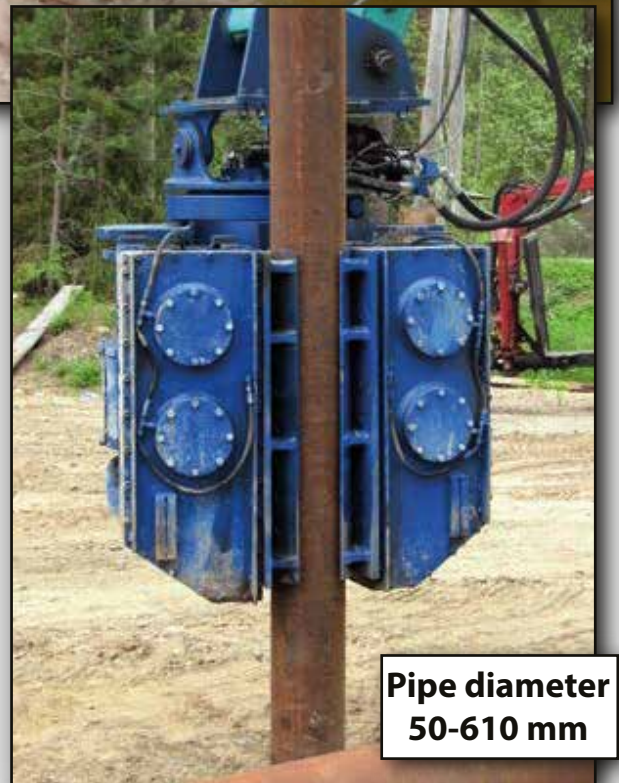

From the **INNOVATOR** of the **1st generation** Side-Grip Piler, now **the 2nd generation available**

The most **advanced** and **productive** Piler on the market: More info, see: www.ramec.fi/1



From the **INNOVATOR** of the 1st generation Side-Grip Piler, now the 2nd generation available

RaMeC SGV from 53hp to 200hp Side-Grip-Vibrator

ONLY RaMeC HAS "THE CENTRIC HIT" SYSTEM

- **Two reasons**, why the RaMeC "centric hit" system is **always** 20% stronger than any other Side-Grip-Vibrator **in the same excavator**

1. The **"dead weight"** in RaMeC is 800kg, in other Side-Grips it is 1,500-2,500kg
The "dead weight" is the weight which the hydraulic motors are accelerating 50 times per second **UP/DOWN**



A Similar example of cars with the same horse power

2. The **vibration force** in the RaMeC-system, is **INSIDE** the pile.
In all competitive system it is 80-90cm (2 feet) outside of the pile
(see more info: www.ramec.fi/2)

- **Only** RaMeC vibrator has following **benefits**

1. Less **ground vibration** (see more info: www.ramec.fi/3)

Very hard ground

- 7m from the building
- measured **ground vibration**: 4-7 mm/s

Note: Max value near historic building = 6 mm/s

Middle hard clay

- 7m from the pile
- measured **ground vibration**: 1-3 mm/s

Note: Max value in city area = 12 mm/s



2. Very **low noise** level: measured even 90db -> **"centric hit"** is not shaking the pile



0-90° angle

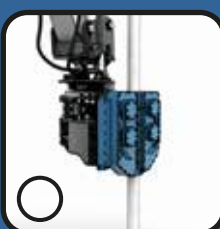

Up to 610 mm pipes

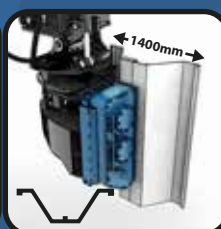

Double "Z" and "U" pile

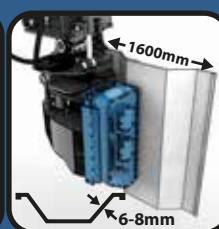

Wide 6-8 mm piles

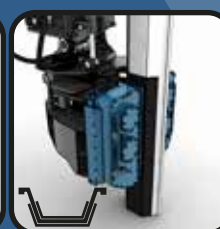

Plastic pile with sandwich-grip



Railway rail without breaking

From the **INNOVATOR** of the 1st generation Side-Grip Piler, now the 2nd generation available

- RaMeC's **LUBRICATION** system

RaMeC is the **SOLE** one of all excavator mountable vibrators, which has full lubrication/cooling system for vibrator bearings.

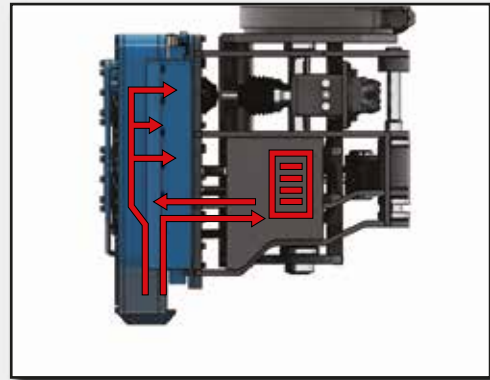
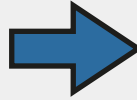

- RaMeC's **CONTROL** system

ONLY RaMeC and the piling rig (the leader rig) are getting the piles straight in all X, Y, Z and R directions.



Do you know any other sheet-pile driver, whose operator is able to drive his 1st pile straight in all X, Y, Z and R directions, and only after **4 hours of training?**

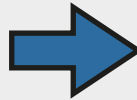

- **ONLY** RaMeC has UP/DOWN hammer

If the vibrator fails, the operator can use the hammer. In two minutes the piler has been changed to **UP/DOWN** hammer and the job can be finished.

This is the most **economical** way to drive piles in to **the silt (london clay, cohesive soil)**, where even 600 to 800 hp vibrators are **failing**

Often the **only** way to extract **jammed/dried** piles

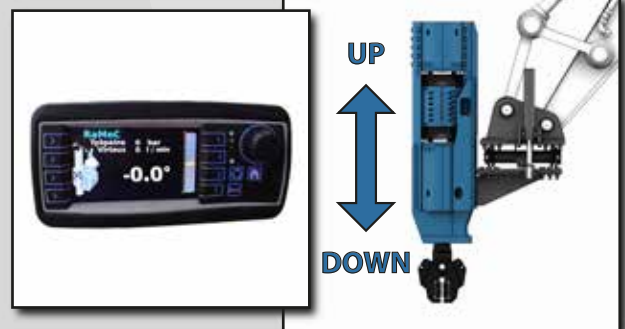
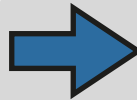

More info, see: www.ramec.fi/4

RaMeC trench piling concept

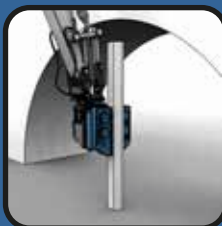

Under low headroom

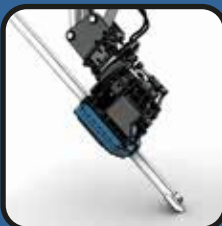

Anchoring



Moving piles



Piling

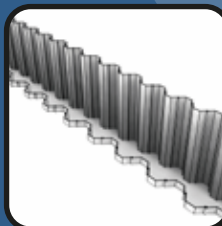

Trench piling and digging





Compacting ground

From the **INNOVATOR** of the 1st generation Side-Grip Piler, now the 2nd generation available

TECHNICAL DATA OF RaMeC SGV:

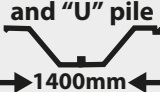
(S = side, G = grip, V = vibrator)

Model in horsepower ¹⁾	RaMeC SGV 50-60 ¹⁾	RaMeC SGV 70 ¹⁾	RaMeC SGV 90 ¹⁾	RaMeC SGV 100 ¹⁾	RaMeC SGV 110 ¹⁾	RaMeC SGV 150 ¹⁾	RaMeC SGV 190 ¹⁾
Weight ²⁾	1600 kg 3200 lb	2400 kg 4800 lb	2500 kg 5000 lb	2500 kg 5000 lb	2550 kg 5100 lb	2600 kg 3200 lb	2650 kg 3300 lb
Hydraulic power (vibra-force ton) ¹⁾	53 hp (30-40)	67 hp (50)	92 hp (60)	104 hp (70)	112 hp (80)	150 hp (90)	190 hp (110)
Excavator class (ton) ³⁾	10-14 ³⁾	16-20 ³⁾	18-20 ³⁾	20-25 ³⁾	25-30 ³⁾	30-36 ³⁾	40-43 ³⁾
Engine power	82 hp	102 hp	141 hp	160 hp	172 hp	221 hp	277 hp
Oil-flow	120 l/min 30 gal/min	120 l/min 30 gal/min	180 l/min 45 gal/min	180 l/min 45 gal/min	180 l/min 45 gal/min	240 l/min 60 gal/min	300 l/min 75 gal/min
Working pressure	200 bar 2900 psi	250 bar 3650 psi	230 bar 3360 psi	260 bar 3650 psi	280 bar 3950 psi	270 bar 3950 psi	270 bar 3950 psi
Pressure setting	250 bar 3650 psi	300 bar 4400 psi	300 bar 4400 psi	300 bar 4400 psi	300 bar 4400 psi	300 bar 4400 psi	300 bar 4400 psi
Pile length	12 m 36 ft	16 m 48 ft	16 m 48 ft	16 m 48 ft	16 m 48 ft	16 m 48 ft	16 m 48 ft
Pile weight	2000 kg 4000 lb	3000 kg 6000 lb	3000 kg 6000 lb	3000 kg 6000 lb	3000 kg 6000 lb	3000 kg 6000 lb	3000 kg 6000 lb
Pipe diameter	324 mm 12 inch	406-610 mm ⁴⁾ 16-24 inch ⁴⁾	406-610 mm ⁴⁾ 16-24 inch ⁴⁾	406-610 mm ⁴⁾ 16-24 inch ⁴⁾	406-610 mm ⁴⁾ 16-24 inch ⁴⁾	406-610 mm ⁴⁾ 16-24 inch ⁴⁾	406-610 mm ⁴⁾ 16-24 inch ⁴⁾
Double "Z" and "U" pile 	No	Special RaMeC	Special RaMeC	Special RaMeC	Special RaMeC	Special RaMeC	Special RaMeC
Wide profile 	No	Special RaMeC	Special RaMeC	Special RaMeC	Special RaMeC	Special RaMeC	Special RaMeC
Plastic piles	Yes	Yes	Yes	Yes	Yes	Yes	Yes
RaMeC's special	Trench ⁵⁾	Trench ⁵⁾	Trench ⁵⁾	Trench ⁵⁾	Trench ⁵⁾	Trench ⁵⁾	Trench ⁵⁾

¹⁾ The "intake" hydraulic power is the only correct way to compare different kind of vibrators. RaMeC "centric hit" is the ONLY vibrator also increasing vibrator's efficiency. RaMeC needs less power for same results

²⁾ Without adapter

³⁾ See the engine power

⁴⁾ Special RaMeC can hit any pipe up to 610mm (24"), double Z-profiles and wide piles

⁵⁾ RaMeC's trench team needs 1 excavator, 1 quick hitch, 1 bucket, **RaMeC, RaMeC drum compactor** and 2 men